

TECHNICAL SPECIFICATION

Piston Size	$\phi 33.96\text{mm} \times 4$	'PL' Dimension	34mm
Piston Area	$18.1\text{cm}^2 \times 2$	Caliper Body	2 pieces
Piston Material	Aluminum Alloy	Caliper Material	Aluminum Alloy Forged
Disc Diameter	$\phi 320(\text{MAX})\text{mm}$		
Disc Thicknesses	$3.5(\text{MIN}) \sim 5(\text{MAX})\text{mm}$		
Weight(Less Pads)	xxxkg		
Hydraulic Threads	M10*1.25		
Mounting	Radial		
- centres	100mm		
- offset	30mm		
- hole ϕ	10.1mm		

PAD FAMILY(PAD-WT01)

Pad Area= 9.7cm^2

Pad Depth= 29.8mm

Pad Thickness - Sintered= 7.4mm (plate thickness 3.2mm)

Pad Weight = 0.19kg (4 pieces)

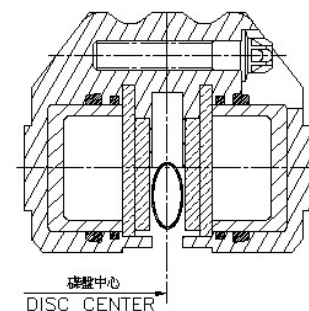
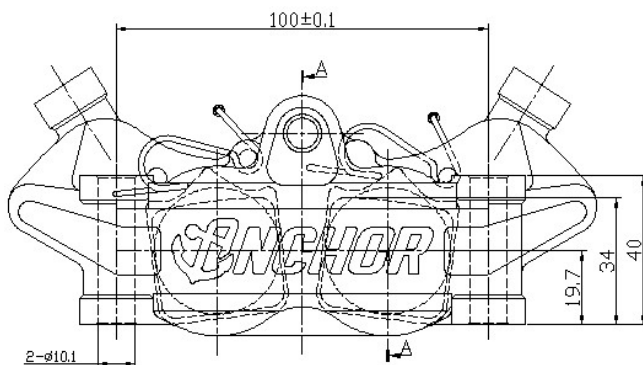
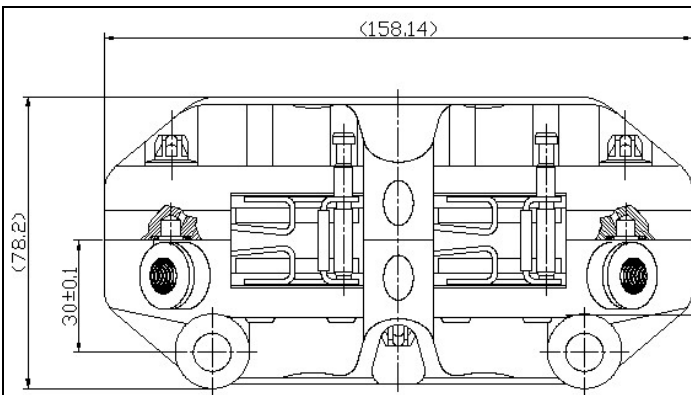
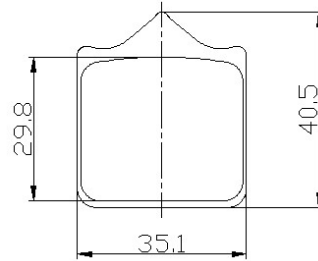

unit:mm