

TECHNICAL SPECIFICATION

Piston Size	$\phi 33.96\text{mm} \times 2$	'PL' Dimension	23.8mm
Piston Area	$9.1\text{cm}^2 \times 2$	Caliper Body	2 pieces
Piston Material	Aluminum Alloy	Caliper Material	Aluminum Alloy CNC
Disc Diameter	$\phi 300(\text{MAX})\text{mm}$		
Disc Thicknesses	3.5(MIN)~5(MAX)mm		
Weight(Less Pads)	0.48kg		
Hydraulic Threads	M10*1.0		
Mounting	Axial(Lug)		
- centres	84mm		
- offset	16mm		
- hole ϕ	8.2mm		

PAD FAMILY(PAD-BW1)

Pad Area=15.6cm²
 Pad Depth=33.2mm
 Pad Thickness - (Organic)=8.2mm(plate thickness 3.2mm)
 - (Sintered)=7.3mm(plate thickness 3.2mm)
 Pad Weight =0.16kg(2 pieces)

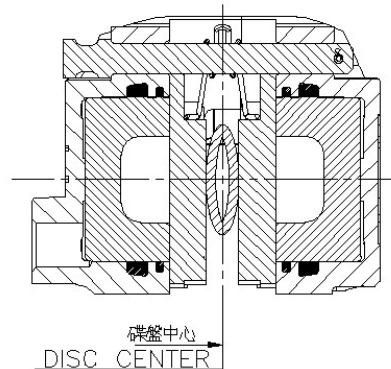
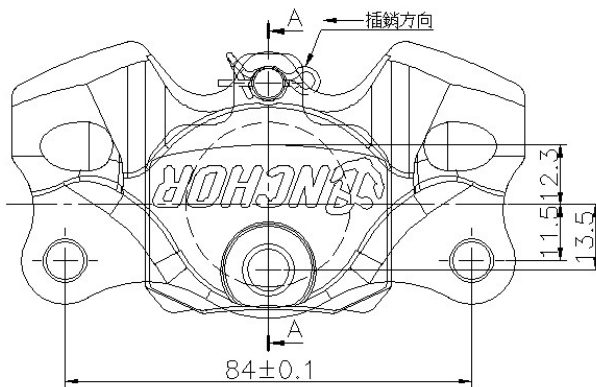
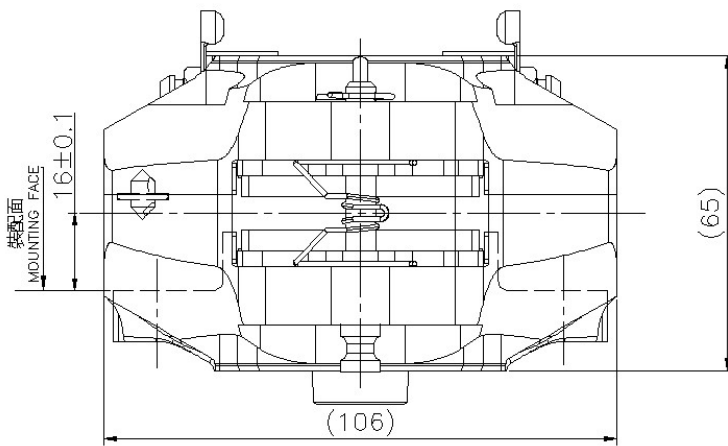
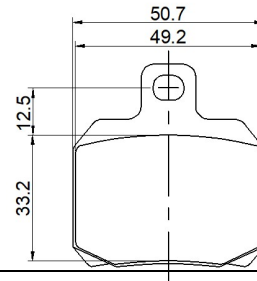

unit:mm