

TECHNICAL SPECIFICATION

Piston Size	ϕ 25.4mm*4	'PL' Dimension	35.77mm
Piston Area	10.1cm ² *2	Caliper Body	2 pieces
Piston Material	Aluminum Alloy	Caliper Material	Aluminum Alloy Forged
Disc Diameter	ϕ 267(MAX)mm		
Disc Thicknesses	3.5(MIN)~6(MAX)mm		
Weight(Less Pads)	0.38kg		
Hydraulic Threads	M10*1.0		
Mounting	Radial		
- centres	82mm		
- offset	20mm		
- hole ϕ	10.1mm		

PAD FAMILY(RG125-PAD)

Pad Area=12.9cm²

Pad Depth=27.1mm

Pad Thickness - Organic=7.3mm(plate thickness 3.2mm)

Pad Weight =0.12kg(2 pieces)

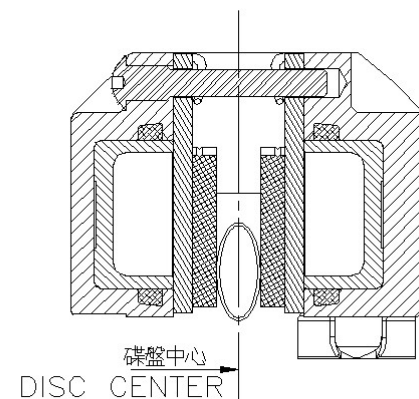
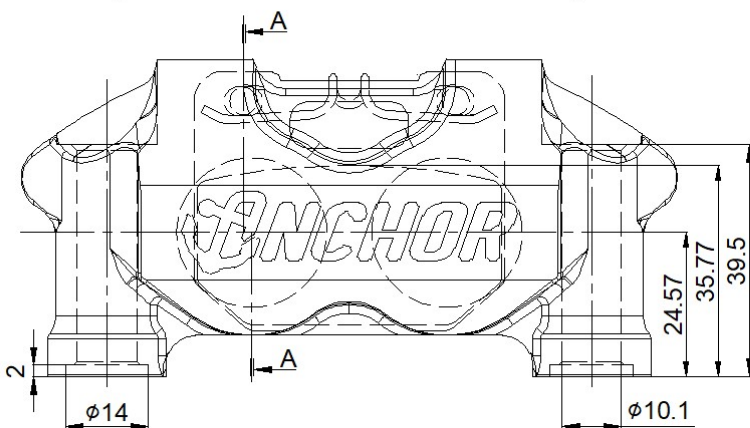
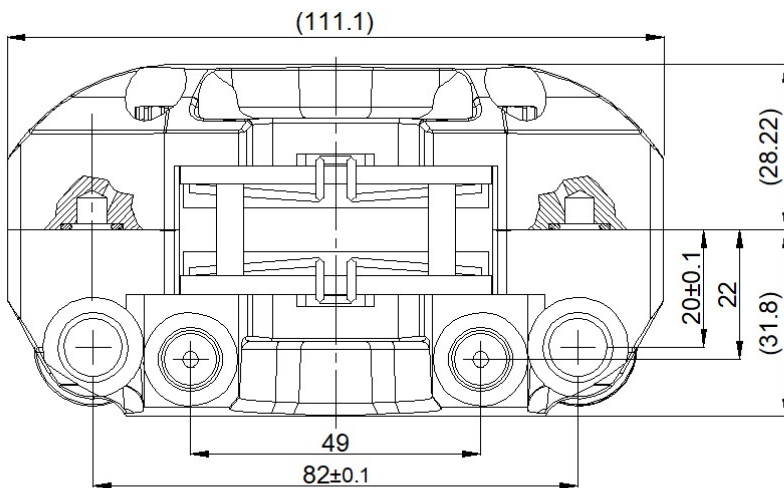
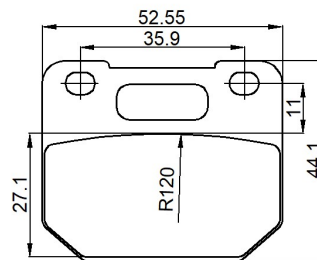

unit:mm