

● BRF4P F+H

TECHNICAL SPECIFICATION

Piston Size	ψ40.45mm*2(Foot Brake) + ψ40.45mm*2(Hand Brake)		
Piston Area	12.85cm ² *2 + 12.85cm ² *2	'PL' Dimension	55.7mm
Piston Material	Aluminum Alloy	Caliper Body	2pieces
Disc Diameter	ψ330~ψ380	Caliper Material	Aluminum Alloy Forged
Disc Thicknesses	T:30mm(T28~T32mm)		
Weight(Less Pads)	3.24kg		
Hydraulic Threads	2*M8*1.25		
Mounting	Radial		
centres	152mm		
offset	48mm		
hole φ	φ 12.2mm		



PAD FAMILY(HF F+H)

Pad Area=48.1cm²
 Pad Depth=41mm
 Pad Thickness=14.5mm(with shim, panel thickness 4.5mm)
 Pad Weight =1.4kg(8pieces)

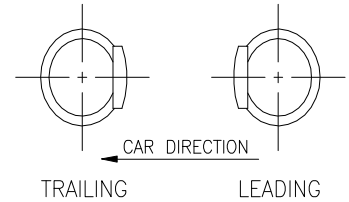

NO	DISC	φB/T	φA	φB	φC	φD	E
1	φ330/30		382.3	330	276.8	211.21	108.3
2	φ355/30		401.3	355	301.8	235.62	120.8
3	φ380/30		428.2	380	328.8	262.08	134.3

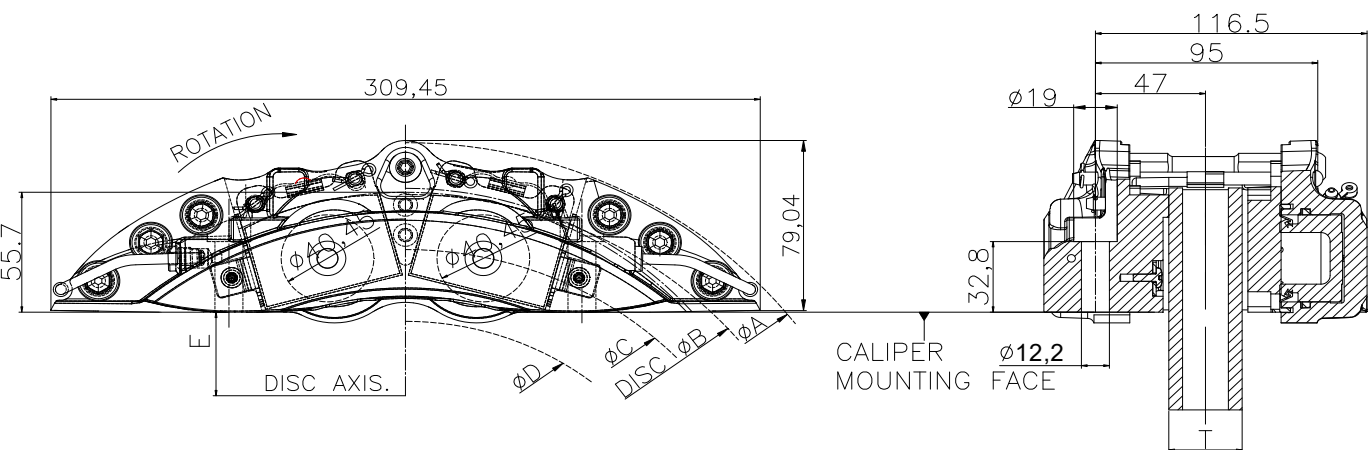
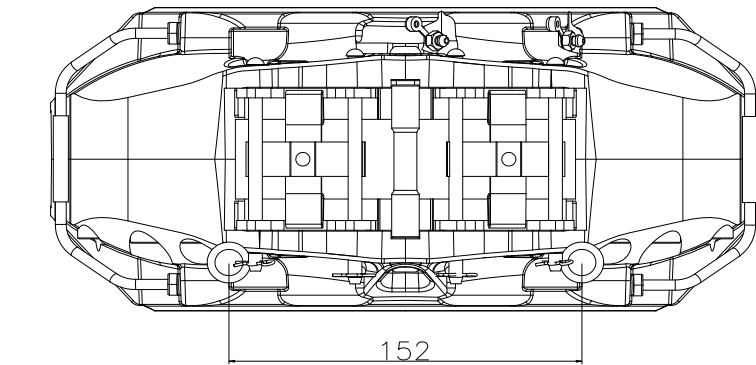

unit:mm

