

TECHNICAL SPECIFICATION

Piston Size	$\phi 30.23\text{mm} * 2 + \phi 33.96\text{mm} * 2$	
Piston Area	$16.2\text{cm}^2 * 2$	'PL' Dimension 52.2mm
Piston Material	Aluminum Alloy	Caliper Body 2 pieces
Disc Diameter	$\phi 320(\text{MAX})\text{mm}$	Caliper Material Aluminum Alloy CNC
Disc Thicknesses	3.5(MIN)~5(MAX)mm	
Weight(Less Pads)	xxxkg	
Hydraulic Threads	M10*1.25	
Mounting	Axial(Lug)	
- centres	65mm	
- offset	32mm	
- threads	M10*1.25	

PAD FAMILY(PAD-ISI06)

Pad Area=20.6cm²

Pad Depth=30.2mm

Pad Thickness - Sintered=8.6mm(panel thickness 3.2mm)

Pad Weight =0.2kg(2 pieces)

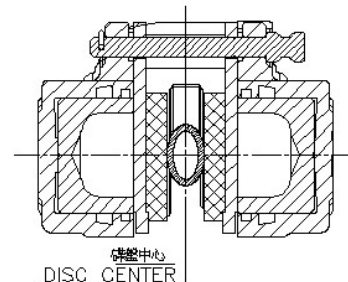
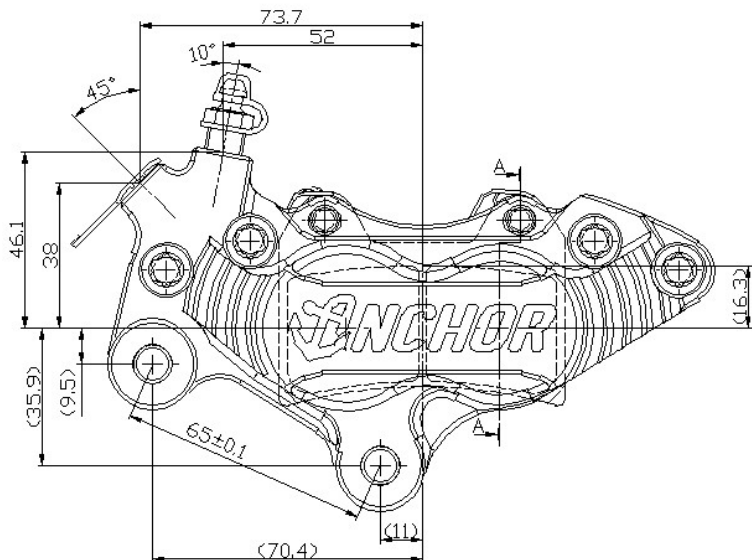
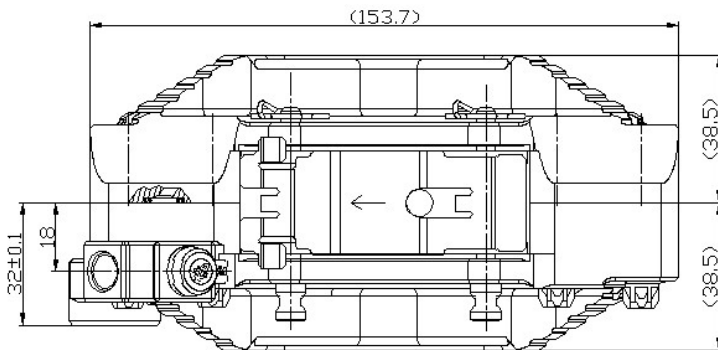
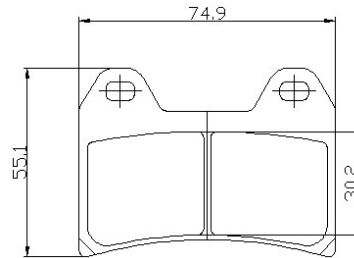

unit:mm