

● R4EPB

TECHNICAL SPECIFICATION

Piston Size	ϕ 30.23mm*4(FOOT BRAKE)+ ϕ 33.96mm*1(HAND BRAKE)		
Piston Area	14.35 cm ² *2	'PL' Dimension	I
Piston Material	Aluminum Alloy	Caliper Body	2pieces
Disc Diameter	ϕ B	Caliper Material	Aluminum Alloy Forged
Disc Thicknesses	T:28mm		
Weight(Less Pads)	6.2kg(One side)		
Hydraulic Threads	M10*1.0		
Mounting	Radial		
centres	154mm		
offset	48.4mm		
hole ϕ	12.2mm		



PAD FAMILY(HF6CPST)

 Pad Area=74.5cm²

Pad Depth=49.5mm

Pad Thickness=15mm(with shim, panel thickness 6mm)

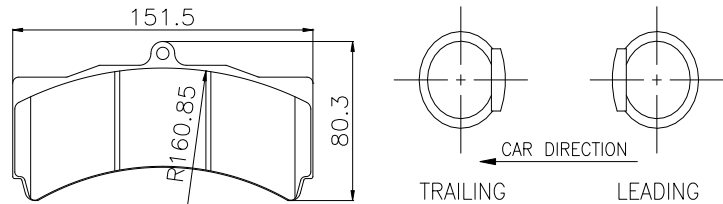
Pad Weight =1.03kg(2pieces)



NO	DISC ϕ B/T	ϕ A	ϕ B	ϕ C	ϕ D	E	I
1	ϕ 355/28	406.21	355	308.84	246.97	108.7	67.8
2	ϕ 380/28	432.71	380	334.61	273.35	123.7	66.3

154MTG HOLE CENTRES

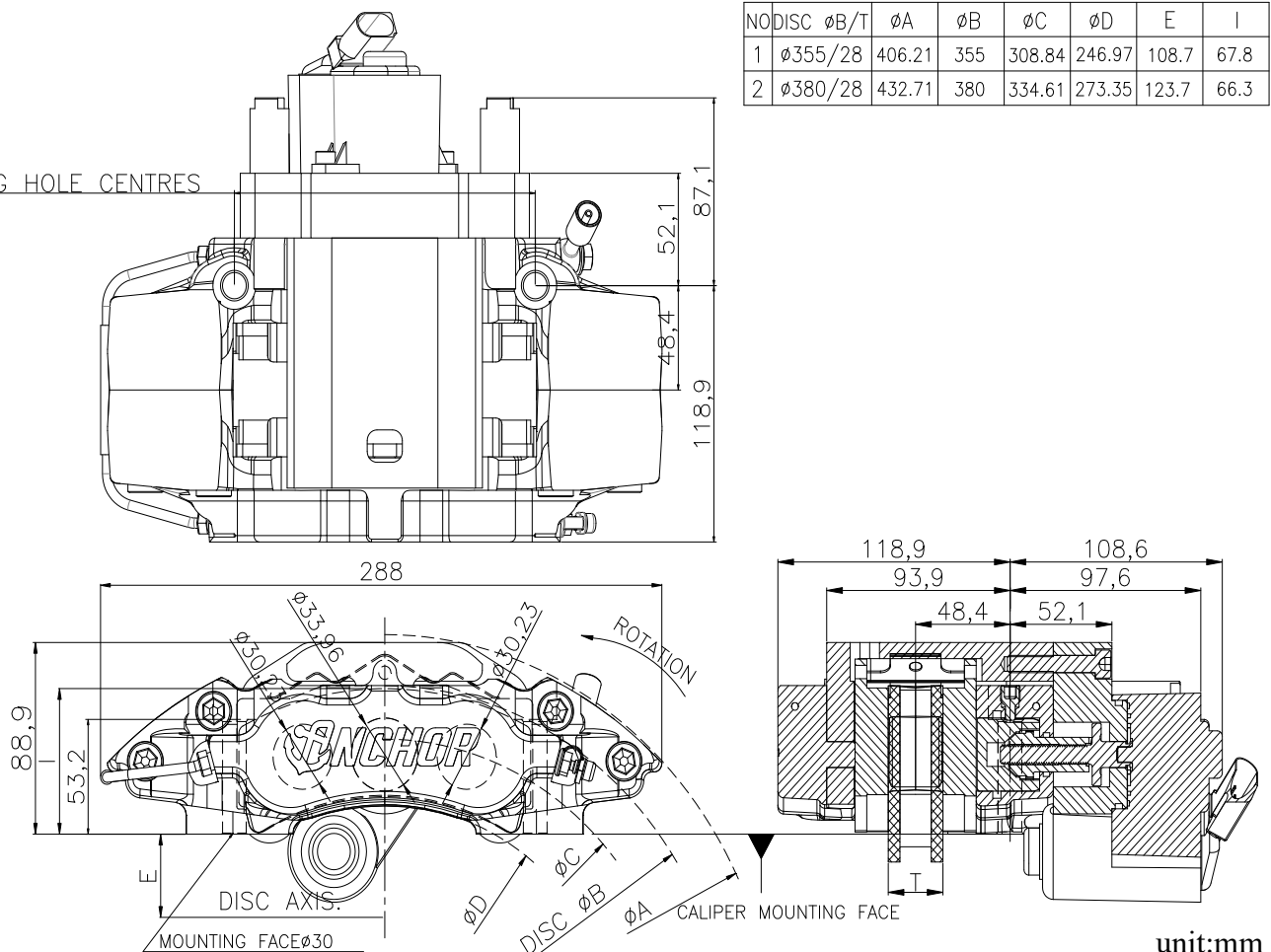

unit:mm



泓輔企業股份有限公司

Horng Fuu Industrial CO.,LTD.