

● BRF4P



LARGE 4 PISTON FORGED CALIPER

大對4 活塞鍛造卡鉗(BRF4P#250)

TECHNICAL SPECIFICATION

| | | | |
|-------------------|--|------------------|-----------------------|
| Piston Size | $\phi 38.18\text{mm} * 2 + \phi 42.85\text{mm} * 2 ; \phi 33.96\text{mm} * 4(\text{REAR})$ | | |
| Piston Area | $25.86\text{cm}^2 * 2 ; 18.1\text{cm}^2 * 2$ | 'PL' Dimension | 55.7mm |
| Piston Material | Aluminum Alloy | Caliper Body | 2 pieces |
| Disc Diameter | $\phi 330\text{mm} \sim \phi 380\text{mm}$ | Caliper Material | Aluminum Alloy Forged |
| Disc Thicknesses | T:30mm(T28~T32mm) | | |
| Weight(Less Pads) | 3.1kg(One side) | | |
| Hydraulic Threads | M10*1.0 | | |
| Mounting | Radial | | |
| - centres | 152mm | | |
| - offset | 47 mm | | |
| - hole ϕ | 12.2mm | | |



PAD FAMILY(HF4BP)

Pad Area=64.2cm²
 Pad Depth=51.2mm
 Pad Thickness=15mm(with shim, panel thickness 5.5mm)
 Pad Weight =1.88kg(4 pieces)

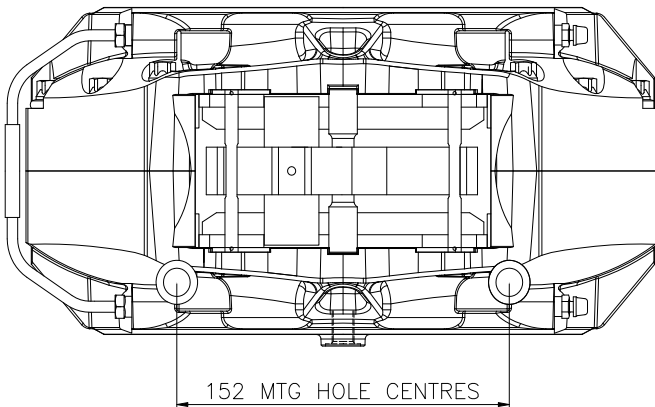
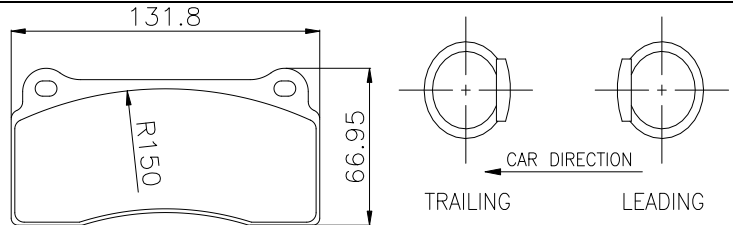

| NO | DISC ϕ B/T | ϕ A | ϕ B | ϕ C | ϕ D | E | F | G | H |
|----|-----------------|----------|----------|----------|----------|-------|----|------|-----|
| 1 | $\phi 330/30$ | 382.3 | 330 | 276.8 | 211.21 | 108.3 | 47 | 93.6 | 116 |
| 2 | $\phi 355/30$ | 401.3 | 355 | 301.8 | 235.62 | 120.8 | 47 | 93.6 | 116 |
| 3 | $\phi 380/30$ | 428.2 | 380 | 328.8 | 262.08 | 134.3 | 47 | 93.6 | 116 |

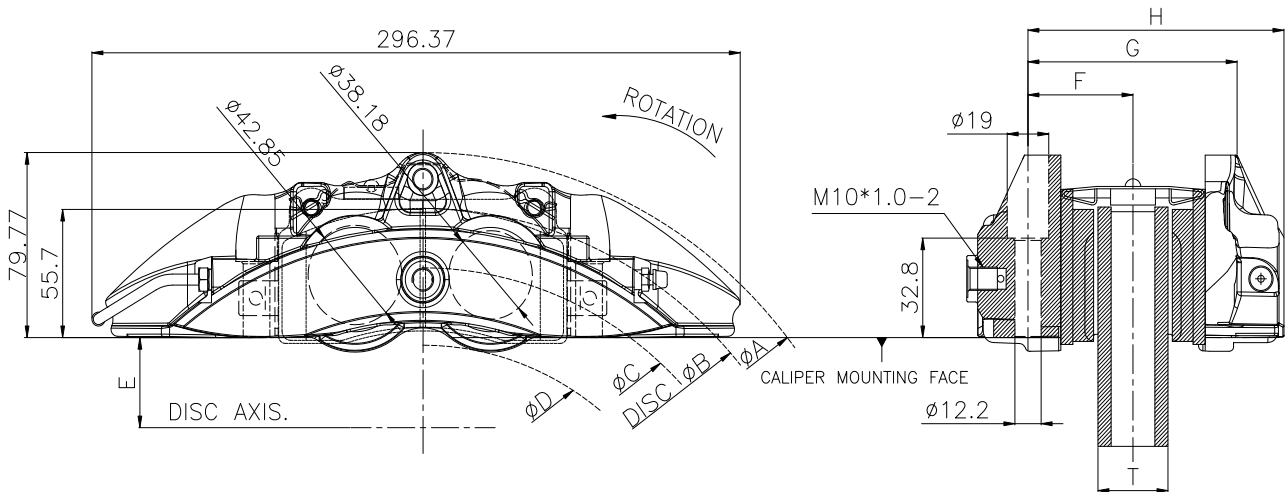

unit:mm

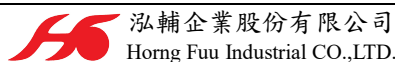

<http://www.anchor-brake.com.tw/>

E-mail: sa2@horngfuu.com.tw

TEL: +886-3-371-0789

FAX: +886-3-371-0777