

TECHNICAL SPECIFICATION

Piston Size	ϕ 30.23mm*4	'PL' Dimension	34.7mm
Piston Area	14.4cm ² *2	Caliper Body	2 pieces
Piston Material	Aluminum Alloy	Caliper Material	Aluminum Alloy Forged
Disc Diameter	ϕ 320(MAX)mm		
Disc Thicknesses	3.5(MIN)~5(MAX)mm		
Weight(Less Pads)	0.71kg		
Hydraulic Threads	M10*1.25		
Mounting	Radial		
- centres	100mm		
- offset	30mm		
- hole ϕ	10.1mm		

PAD FAMILY(59-110)

Pad Area=21.77cm²
 Pad Depth=34mm
 Pad Thickness - Organic=8.5mm(plate thickness 3mm)
 - Sintered=8mm(plate thickness 3.2mm)
 Pad Weight =0.19kg(2 pieces)

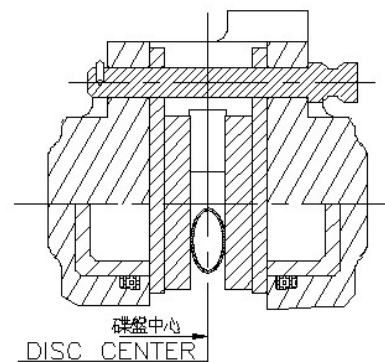
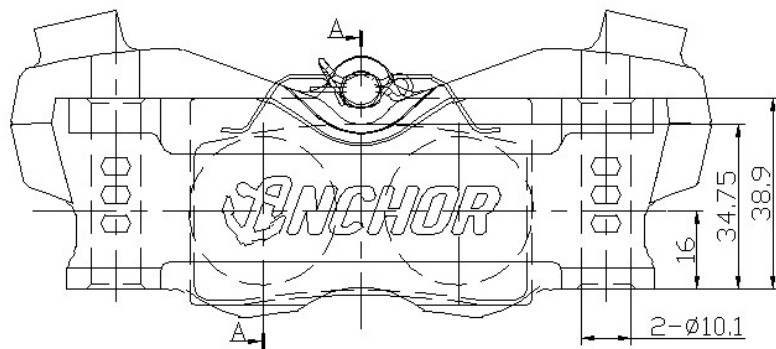
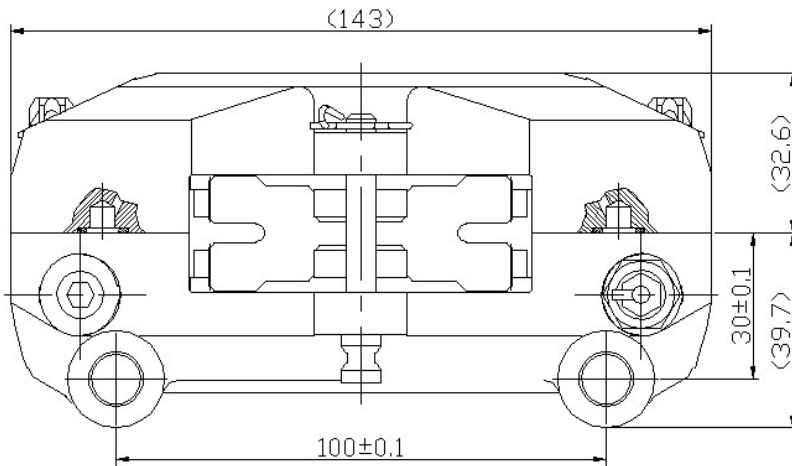
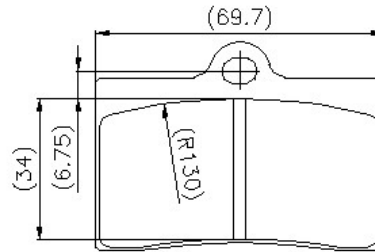

unit:mm