

TECHNICAL SPECIFICATION

Piston Size	$\phi 40.45\text{mm} * 2 + \phi 42.85\text{mm} * 2 ; \phi 33.96\text{mm} * 4$		
Piston Area	$27.27\text{cm}^2 * 2 ; 18.12\text{cm}^2 * 2$	'PL' Dimension	55.7mm
Piston Material	Aluminum Alloy	Caliper Body	2 pieces
Disc Diameter	ϕB	Caliper Material	Aluminum Alloy Forged
Disc Thicknesses	T:28mm		
Weight(Less Pads)	3.1kg(One side)		
Hydraulic Threads	M10*1.0		
Mounting	Radial		
- centres	152mm		
- offset	F mm		
- hole ϕ	12.2mm		



PAD FAMILY(HF4BPST)

Pad Area=64.2cm²
 Pad Depth=51.2mm
 Pad Thickness=13.5mm(with shim, panel thickness 5.5mm)
 Pad Weight =1.88kg(4 pieces)

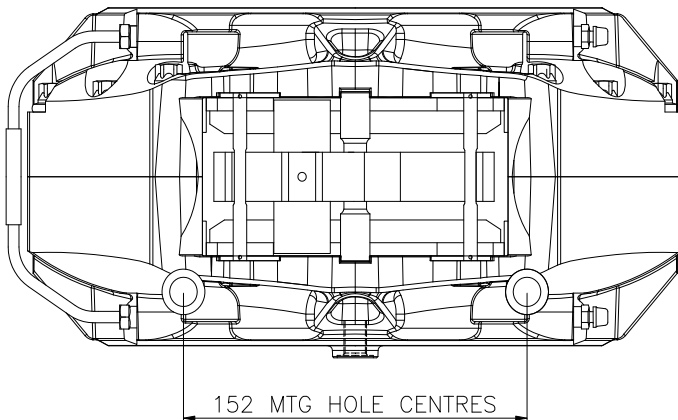
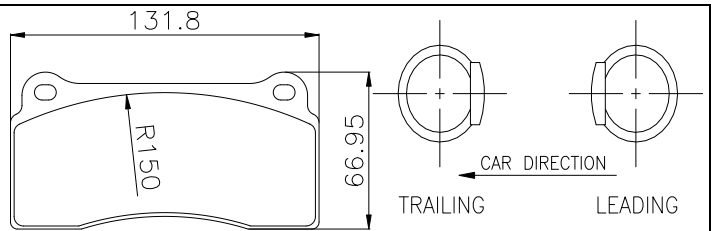

NO	DISC $\phi B/T$	ϕA	ϕB	ϕC	ϕD	E	F	G	H
1	$\phi 330/T28$	382.3	330	276.8	211.21	108.3	44	85.7	106
2	$\phi 355/T28$	401.3	355	301.8	235.62	120.8	44	85.7	106
3	$\phi 380/T28$	428.2	380	328.8	262.08	134.3	44	85.7	106

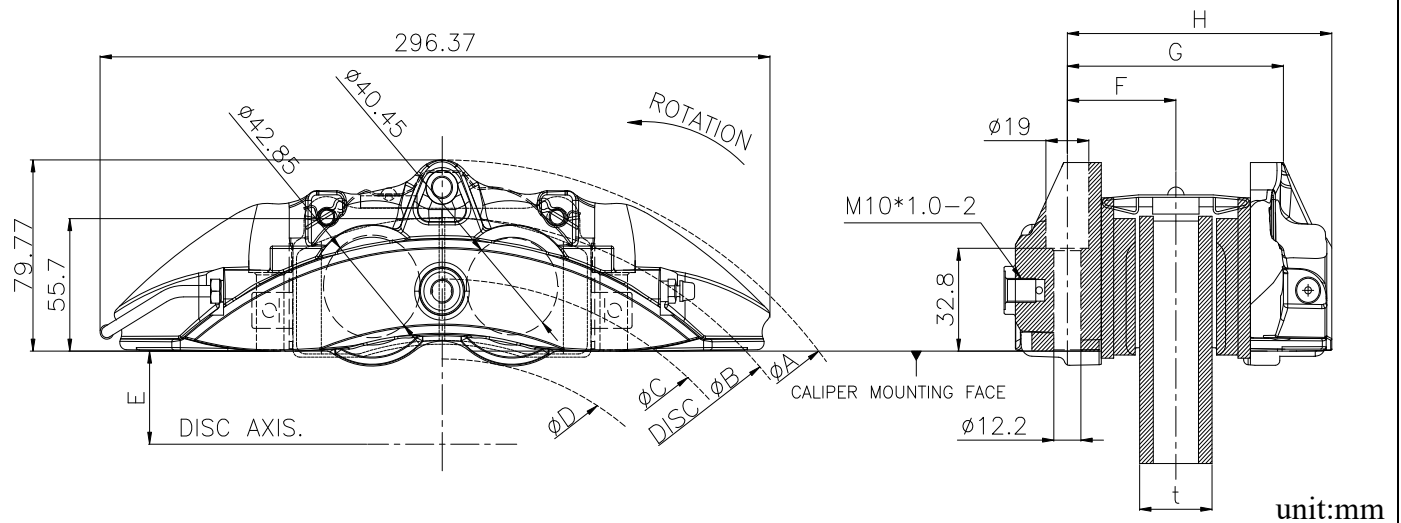

unit:mm