

● N4PSTR



MEDIUM 4 PISTON FORGED CALIPER ST SERIES

中對 4 活塞鍛造卡鉗 ST 系列(N4PST#270STR)

TECHNICAL SPECIFICATION

Piston Size	ϕ 33.96mm*4(REAR)	'PL' Dimension	55.25mm
Piston Area	18.12cm ² *2	Caliper Body	2 pieces
Piston Material	Aluminum Alloy	Caliper Material	Aluminum Alloy Forged
Disc Diameter	ϕ 290~ ϕ 355		
Disc Thicknesses	T:11 mm(Max:13mm)		
Weight(Less Pads)	2.8kg(One side)		
Hydraulic Threads	M10*1.0		
Mounting	Radial		
- centres	130mm		
- offset	36mm		
- hole ϕ	12.2mm		



PAD FAMILY(HFN4ST)

Pad Area=59cm²
 Pad Depth=46.5mm
 Pad Thickness=13.5mm(with shim, panel thickness 5.5mm)
 Pad Weight =0.85kg(2 pieces)

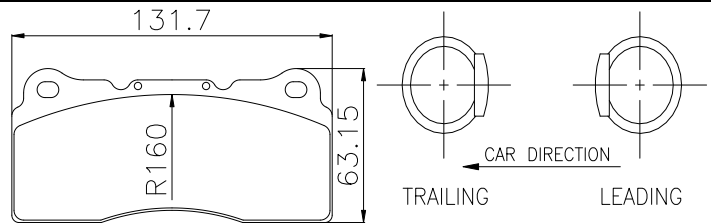

NO	DISC ϕ B/T	ϕ A	ϕ B	ϕ C	ϕ D	E
1	ϕ 290/T11	343.5	290	241.5	186.3	88.7
2	ϕ 355/T11	401	355	308.5	251	122.2

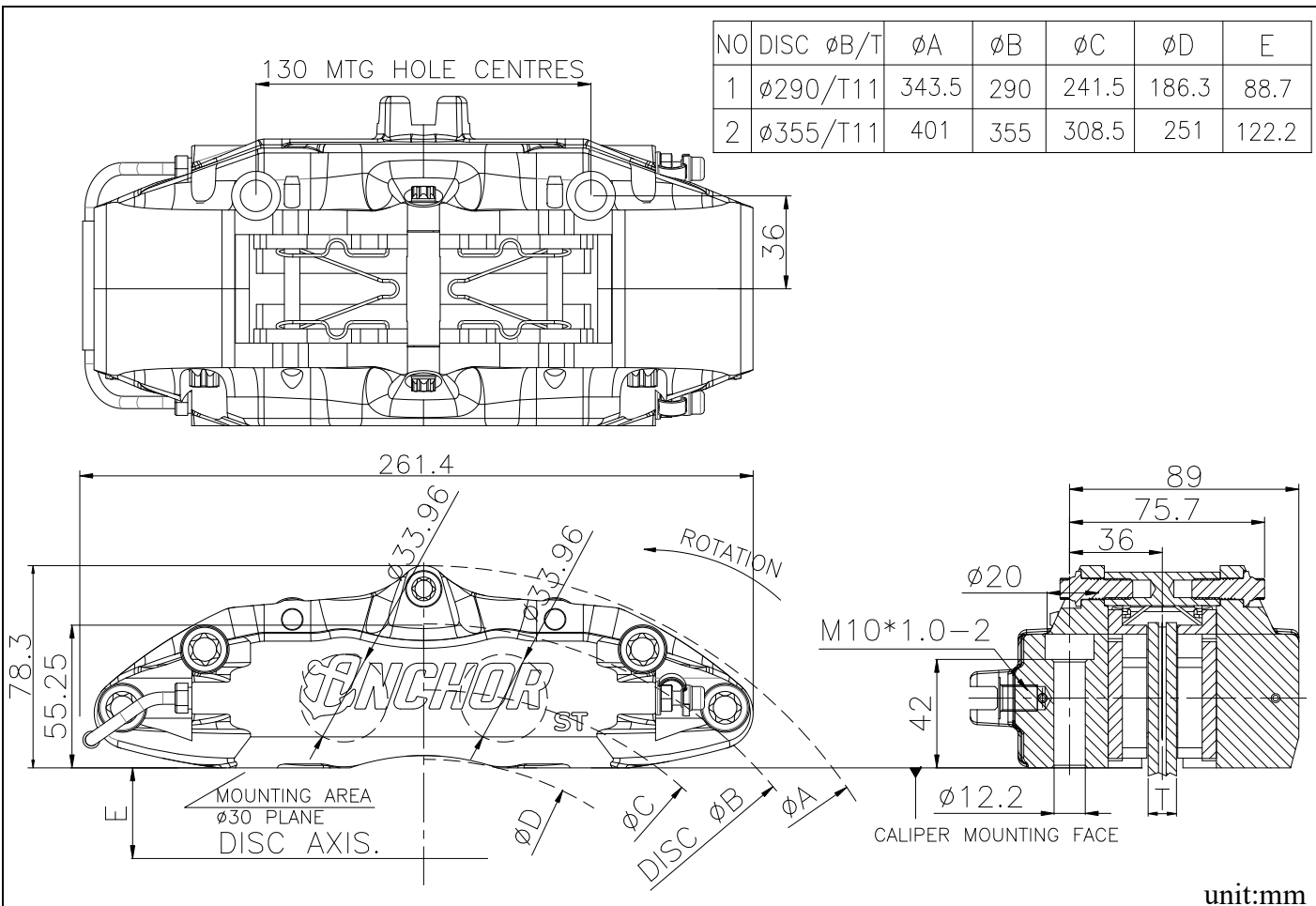

unit:mm

