

● 4FMP2

TECHNICAL SPECIFICATION

Piston Size	ϕ 40.45mm*4	'PL' Dimension	55.81mm
Piston Area	25.7cm ² *2	Caliper Body	2pieces
Piston Material	Aluminum Alloy	Caliper Material	Aluminum Alloy Forged
Disc Diameter	ϕ B		
Disc Thicknesses	T:24mm(T22~T26mm)		
Weight(Less Pads)	2.3kg(One side)		
Hydraulic Threads	M10*1.0		
Mounting	Radial		
centres	130mm		
offset	44mm		
hole ϕ	12.2mm		



PAD FAMILY(HF4CMP1)

 Pad Area=47.3cm²

Pad Depth=45mm

Pad Thickness=13.5~15mm(with shim, panel thicknes 5.5mm)

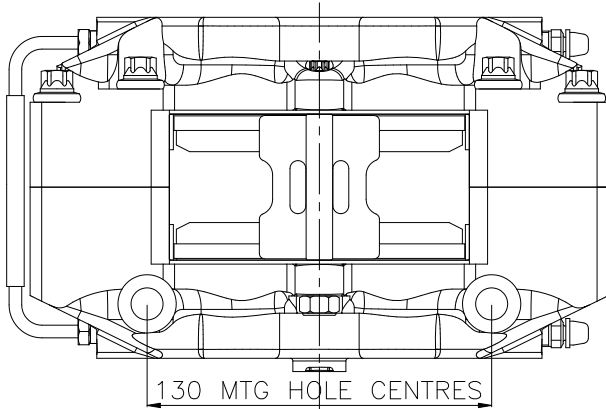
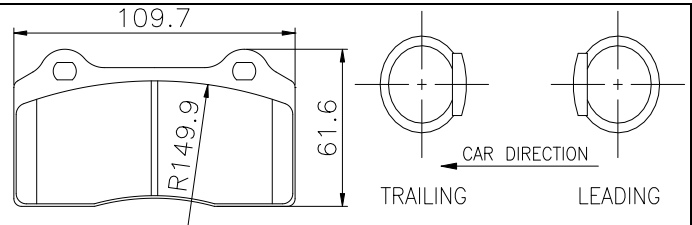
Pad Weight =0.68kg(2pieces)



NO	DISC	ϕ B/T	ϕ A	ϕ B	ϕ C	ϕ D	E
1	ϕ 282	T24	326	282	230.4	172.64	83.9
2	ϕ 303	T24	346	303	252.1	194.36	94.9

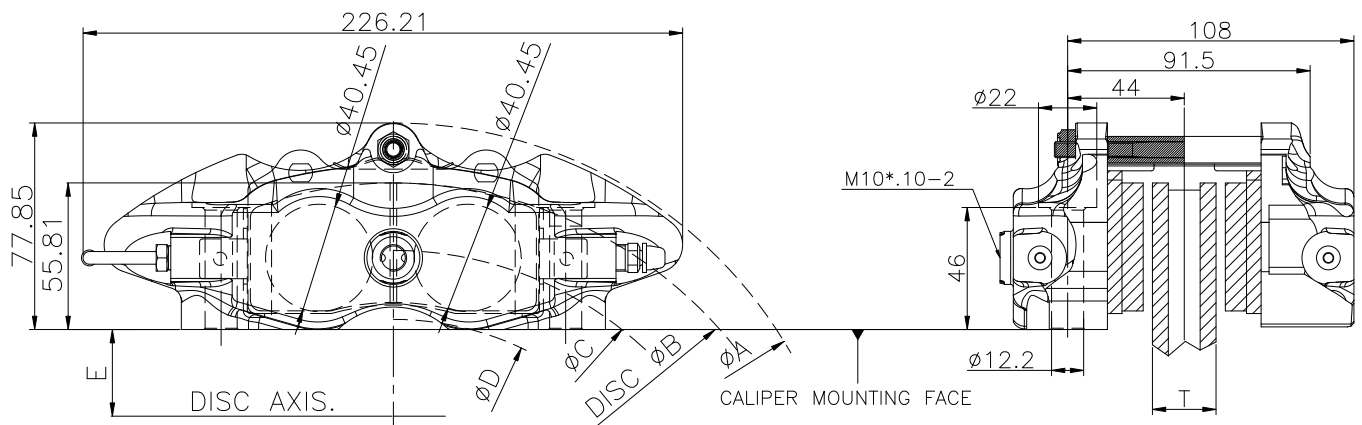

unit:mm

