

● 8FP

TECHNICAL SPECIFICATION

Piston Size	ϕ 30.23mm*4+ ϕ 33.96mm*4		
Piston Area	32.47cm ² *2	'PL' Dimension	67.13mm
Piston Material	Aluminum Alloy	Caliper Body	2 pieces
Disc Diameter	ϕ B	Caliper Material	Aluminum Alloy Forged
Disc Thicknesses	T		
Weight(Less Pads)	4.85kg(One side)		
Hydraulic Threads	M10*1.0		
Mounting	Radial		
- centres	200mm		
- offset	54.4mm		
- hole ϕ	12.2mm		



PAD FAMILY(HF8CP)

Pad Area=45.2cm²
 Pad Depth=56.8mm
 Pad Thickness=16.5mm(with shim, panel thickness 5.5mm)
 Pad Weight =1.4kg(4 pieces)

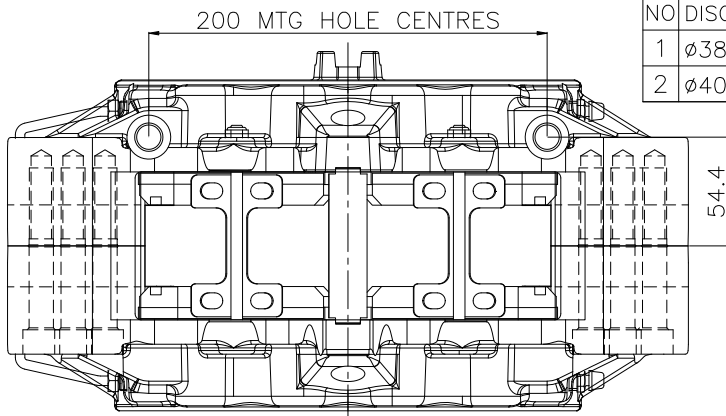
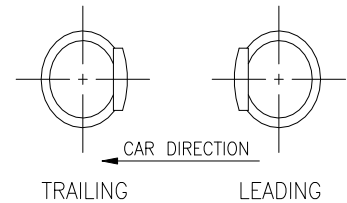
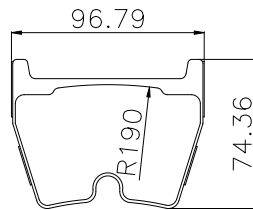

NO	DISC ϕ B/T	ϕ A	ϕ B	ϕ C	ϕ D	ϕ E	F
1	ϕ 380/T34	433.58	380	319.84	258.82	250.82	121.53
2	ϕ 405/T36	456.17	405	344.67	282.71	276.86	135.03

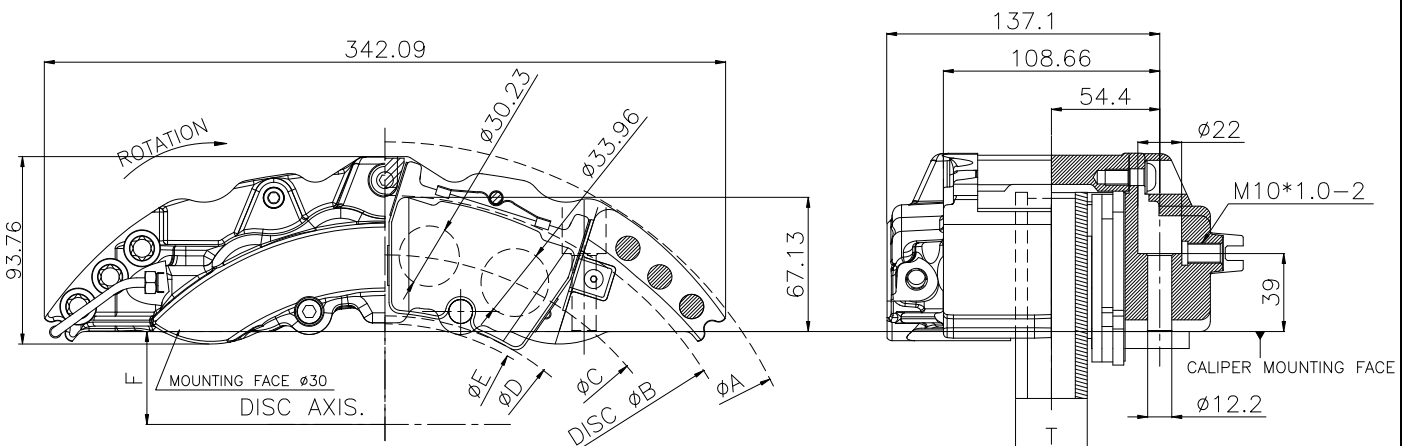

unit:mm