

● 12FP

TECHNICAL SPECIFICATION

Piston Size	$\phi 27\text{mm} \times 12$	'PL' Dimension	80.85mm
Piston Area	$34.35\text{cm}^2 \times 2$	Caliper Body	2pieces
Piston Material	Aluminum Alloy	Caliper Material	Aluminum Alloy Forged
Disc Diameter	ϕB		
Disc Thicknesses	T		
Weight(Less Pads)	5.15kg(One side)		
Hydraulic Threads	M10*1.0		
Mounting centres	250mm		
offset	54.4mm		
hole ϕ	12.1mm		



PAD FAMILY(HF12CP)

Pad Area=33cm²
 Pad Depth=50.3mm
 Pad Thickness=16.5mm(with shim, panel thickness 5.5mm)
 Pad Weight =1.5kg(6pieces)

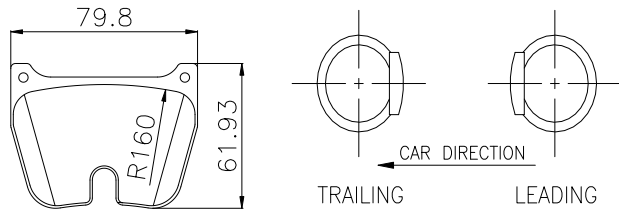

NO	DISC $\phi B/T$	ϕA	ϕB	ϕC	ϕD	ϕE	F
1	$\phi 380/T34$	440.66	380	335.15	278.47	273.43	107.35
2	$\phi 405/T36$	455	405	361.58	302.17	299.59	120.65

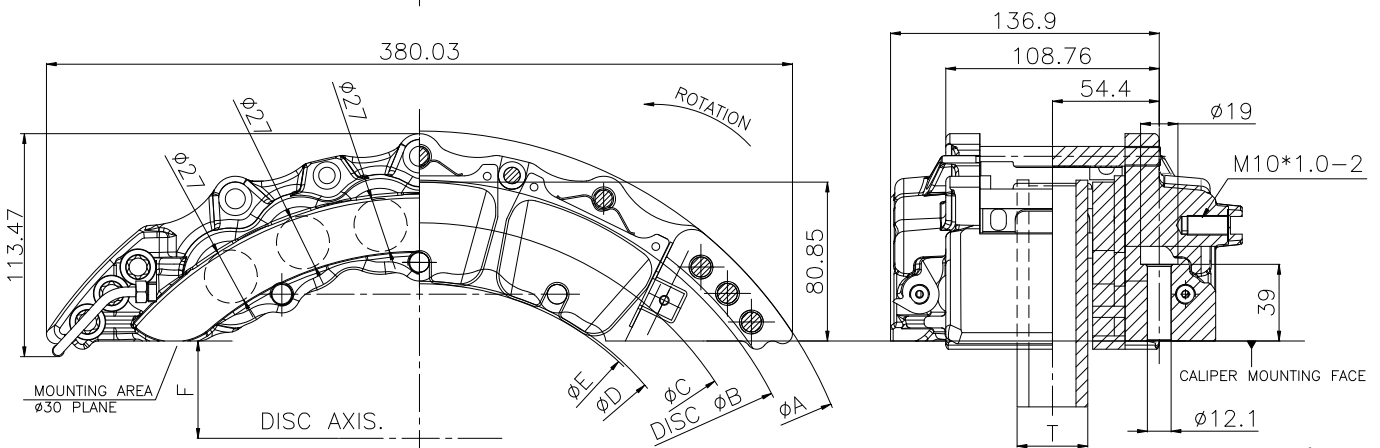
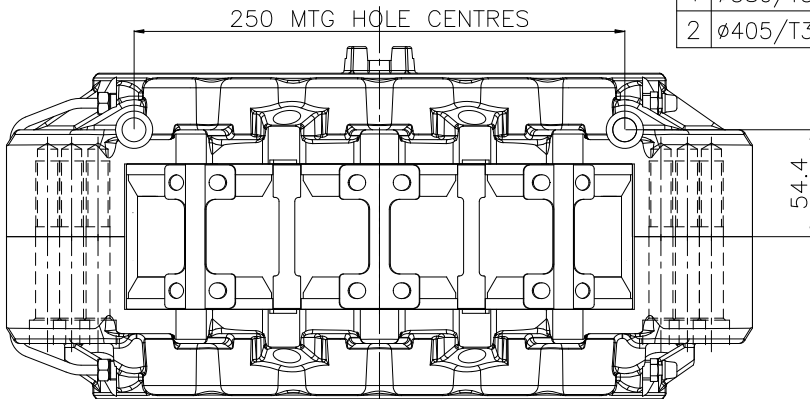

unit:mm